

AOP-CPT.ADA - Cambridge Picnic Table, ADA

Material

The Cambridge ADA Picnic Table is made of 2-1/2" Square OD 18 gage powder coated steel with 2"x 10" recycled plastic planks for the bench and table. The picnic table is 6ft long.

The Cambridge is available in a surface mount option with pre-drilled holes in the feet to prevent movement as well as an in-ground mounting option. Mounting hardware is not included.

The recycled planks are made from at least 95% recycled materials and is Green Circle Certified. These planks are resistant to fading, sagging and splintering and will never need painting.

Powder Coated Steel Frame

Tubular components go through an extensive powder coating process adding additional protection making our steel frames highly resistant to rust.

Color

We offer the Cambridge in Cedar or Dark Grey 2" x 10" recycled plastic boards. Visit website for more information.

Assembly

Hardware included. Some assembly required. (Optional pre-assembly if desired, call for more info.)

Warranty

All product warranties take effect at the date of purchase. All of our products are under warranty for 1 year, products with extended warranties will be listed on that specific product page. Should any failure occur within the warranty period, please notify us so we can resolve the issue promptly! Additional warranty information is available on our website.

Maintenance

The Cambridge Picnic Table is essentially maintenance free. Cleaning is simple as wiping the product down with soap and water.

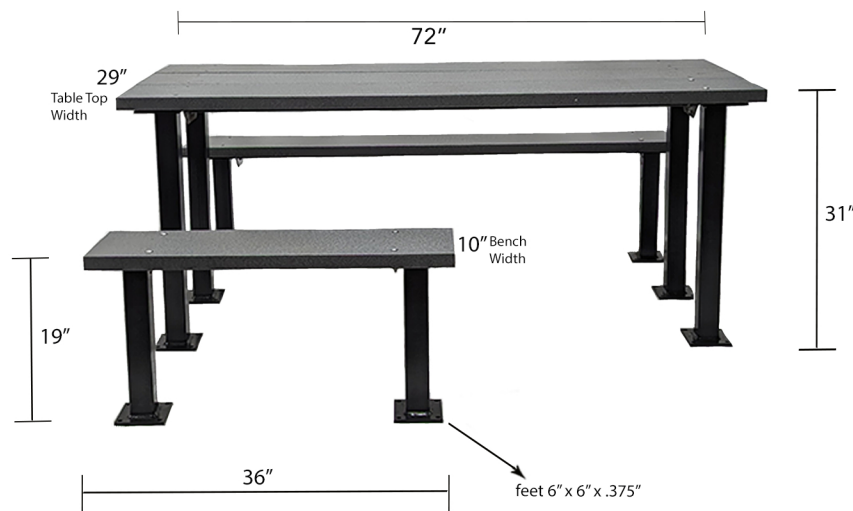

SHIPPING INFORMATION

per 1 picnic table

Unit Weight(1)	Shipping Class	Shipping Dimensions	Shipping Weight (w/pallet)
314 lbs Table & Benches	50	80" L x 45" W x 25" H	362 lbs